

Supported by  日本 THE NIPPON
財団 FOUNDATION

The 7th ASEF

KOBE, JAPAN

Date: 7-8 November 2013
Venue: Kobe Meriken Park Oriental Hotel



The Shipbuilders' Association of Japan



Japan Ship Technology Research Association

Programme

Day 1 Thursday, 7 November

Registration desk opens at 9:00 am

◆ **Plenary Session 9:30-12:30** ➡ **Room ZUITEN**

Chaired by Mr. Dave Iwamoto, The Shipbuilders' Association of Japan (SAJ)

- 09:30-09:40 **Opening address**
Mr. Akira Matsuda, Chairman, Japan Ship Technology Research Association (JSTRA)
- 09:40-09:50 **Welcome speech**
Mr. Shigeru Murayama, Vice Chairman, SAJ / President, Kawasaki Heavy Industries, Ltd. (KHI)
- 09:50-10:20 **Keynote speech**
'Recent development of maritime rules and the roles of ASEF'
Mr. Norihisa Fukuda, Chairman of Technical Affairs Committee, SAJ / Director, Mitsui Engineering & Shipbuilding Co., Ltd. (MES)
- 10:20-10:40 Tea/Coffee break
- 10:40-11:10 **Report of the correspondence group on IMO-NGO issue**
Mr. Bin Okamura, Coordinator of the CG on IMO-NGO issue
- 11:10-11:30 **Report of the correspondence group on IHM**
Mr. Muneharu Toyota, Coordinator of the CG on IHM
- 11:30-11:50 **Presentation by the representative of Association of Asian Classification Societies (ACS)**
'ACS activities and future direction related to IMO'
Dr. Toshiro Arima, General Manager of External Affairs Division, ClassNK
- 11:50-12:10 **Presentation by the representative of Asian Shipowners' Forum (ASF)**
'Recent Issues for International Shipping'
Mr. Yuich Sonoda, Secretary General, ASF
- 12:10-12:30 **Presentation by Asian Shipbuilding Industry**
'Current situation of Colombo Dockyard'
Mr. D V Abeysinghe, General Manager (Projects & Engineering), Colombo Dockyard PLC

◆ **Lunch Break 12:30-14:00** ➡ **Room KAIO**

◆ *Afternoon Parallel Sessions 14:00-18:00* ➡ *Room ZUITEN*

Safety Session

Chaired by Mr. Wu Jiameng (Marine Design & Research Institute of China (MARIC))

Gas fuelled ship	
1	“EcoNuri” the first LNG fuelled-ship in Asia’ Mr. Jaemoo Lee, Samsung Heavy Industries, Korea
2	‘Environmentally Superior Vessels with LNG as Fuel; Achievements and Prospects for the Near Future’ Mr. Takashi Unseki, Mitsubishi Heavy Industries, Ltd., Japan
Testing arrangements for watertight compartments	
3	‘Introduce on tests of tanks and tight boundaries’ Mr. Bai Yugang, China Ship Design and Research Centre Co., Ltd., China
GBS / CSR-H, SCF	
4	‘Consequence Assessment on Harmonized CSR (April version) from Chinese Shipbuilding Industry’ Mr. Wen Baohua, GreenSeas Marine Technology Co., Ltd., China
5	‘Consequence assessment of Harmonized CSR by the Shipbuilders’ Association of Japan’ Mr. Toshihiro Fujii, Oshima Shipbuilding Co., Ltd., Japan
6	‘GBS-IPR Development of the Ship Construction File (SCF) industry standards’ Mr. Kenji Kamita, Imabari Shipbuilding Co., Ltd., Japan
Liquefaction of bulk cargo	
7	‘Introduction of the ClassNK Activities for the Safe Carriage of Nickel Ore’ Mr. Yuki Tamura, ClassNK, Japan

Environment Session

Chaired by Mr. Choi Byeong-cheol (Korea Offshore and Shipbuilding Association (KOSHIPA))

GHG	
1	‘On the current correction method of sea trial tests’ Dr. Myung Soo Shin, Korea Institute of Ocean Science & Technology, Korea
2	‘Current status on revision work of ISO15016 for EEDI verification - Conduct and analysis procedure of speed trial-’ Mr. Tsuyoshi Ishiguro, Japan Marine United Corporation, Japan
Air Pollution	
3	‘Effect of SOx and NOx Regulation / Implementation, ECA’s and NOx Tier III / Current Developments in General’ Mr. Toru Nakao, Hitachi Zosen Corporation, Japan
4	‘Latest technologies for environmental measure in 2 stroke diesel engine’ Mr. Naohiro Hiraoka, Mitsubishi Heavy Industries Marine Machinery & Engine Co., Ltd , Japan
BWM	
5	‘DSIC Research and Design on Less Ballast Water Ships’ Mr. Bao Yan, Dalian Shipbuilding Industry Engineering and Research Institute, China
6	‘Application of photo-catalytic technology in ship’s ballast water treatment’ Mr. Zhang Daiyi, 6354 Institute of China State Shipbuilding Corporation, China

◆ *Welcome Dinner 19:00- ☞ Cruise Ship “CONCERTO”*

Day 2 Friday, 8 November

◆ *Wrap-up Session 9:30-12:00* ➡ *Room ZUITEN*

Chaired by Mr. Dave Iwamoto, SAJ

- 09:30-09:50 **Presentation on External relationships of ASEF including IMO's FSSS**
Mr. O Kitamura, Mitsubishi Heavy Industries, Ltd., SAJ
- 09:50-10:20 **Report of the Safety session**
Mr. Wu Jiameng, MARIC
- 10:20-10:50 **Report of the Environment session**
Mr. Choi Byeong-cheol, KOSHIPA
- 10:50-11:00 **Announce on the next annual conference of ASEF**
Host of the 8th ASEF
- 11:00-11:20 Tea/Coffee break
- 11:20-11:50 **Conclusion of the 7th ASEF**
Mr. Dave Iwamoto, Chair of the 7th ASEF
- 11:50-12:00 **Closing address**
Mr. Nobuyoshi Aikawa, President, JSTRA

◆ *Lunch 12:00-13:00* ➡ *Room KAIO*

Floor Plan

4th floor, Kobe Meriken Park Hotel

Registration desk is located at the entrance of Room ZUITEN.

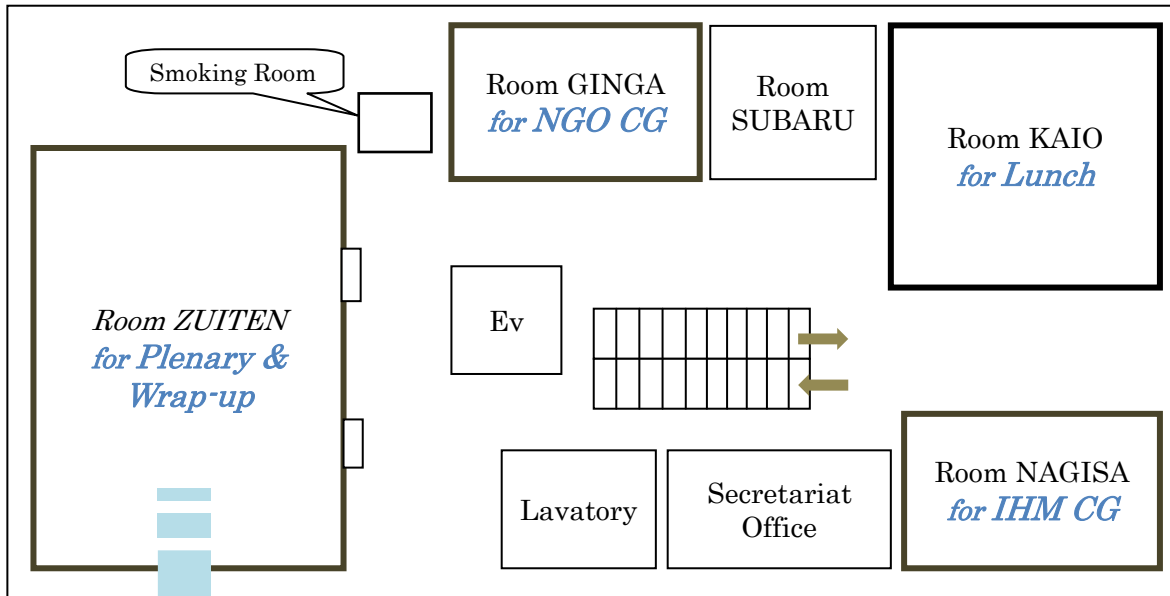

Attention!

During lunch time of Day 1, Room ZUITEN is partitioned into two rooms for afternoon parallel sessions.



第1日 11月7日 (木)

受付・登録 9:00 から

◆ 全体会合 9:30-12:30 於 瑞天 議長：岩本 洋（一般社団法人日本造船工業会）

- 09:30-09:40 開会の辞
松田 章（一般財団法人日本船舶技術研究協会会長）
- 09:40-09:50 歓迎の辞
村山 滋（一般社団法人日本造船工業会副会長 / 川崎重工業株式会社社長）
- 09:50-10:20 基調講演 「最近の海事規則の動向とASEFの役割」
福田 典久（一般社団法人日本造船工業会技術委員長 / 三井造船株式会社
取締役船舶・艦艇事業本部長）
- 10:20-10:40 休憩
- 10:40-11:10 IMO-NGOに関するCGの報告
岡村 敏（IMO-NGO CG コーディネーター）
- 11:10-11:30 IHMに関するCGの報告
豊田 宗晴（IHM-CG コーディネーター）
- 11:30-11:50 アジア船級協会連合（ACS）によるプレゼンテーション
「ACSの活動とIMOに関する今後の方向性」
有馬 俊朗（一般財団法人日本海事協会国際室長）
- 11:50-12:10 アジア船主フォーラム（ASF）によるプレゼンテーション
「国際海運の最近の課題」
園田 裕一（ASF事務局長）
- 12:10-12:30 アジア造船業によるプレゼンテーション
「コロンボ造船の最新状況」
Mr. D V Abeyasinghe (General Manager, Colombo Dockyard PLC)

◆ 昼食 12:30-14:00 於 海王

◆ 午後の部 分科会 14:00-18:00 於 瑞天

安全分科会

議長 Mr. Wu Jiameng (Marine Design & Research Institute of China (MARIC))

ガス燃料船	
1	「アジアにおける LNG 燃料船第 1 号『EcoNuri』 Mr. Jaemoo Lee (Samsung Heavy Industries)、韓国
2	「環境に優れた LNG 燃料船－現状と今後の見通し」 雲石 隆司 (三菱重工業株式会社)、日本
水密区画の検査方法	
3	「タンクと水密区画の検査方法」 Mr. Bai Yugang (China Ship Design & Research Center Co., Ltd.)、中国
目標指向型規則/調和共通構造規則、船舶建造ファイル	
4	「中国造船業界による調和共通構造規則 (4 月版) の影響評価」 Mr. Wen Baohua (GreenSeas Marine Technology Co., Ltd.)、中国
5	「日本造船工業会に調和共通構造規則の影響評価」 藤井 壽裕 (株式会社大島造船所)、日本
6	「GBS-IPR 船舶構造ファイル (SCF) 業界標準の策定」 紙田 健二 (今治造船株式会社)、日本
ばら積み貨物の液状化	
7	「ニッケル鈹の安全輸送に向けた日本海事協会の取組み」 田村 悠樹 (一般財団法人日本海事協会)、日本

環境分科会

議長 Mr. Choi Byeong-cheol (KOSHIPA)

温室効果ガス	
1	「海上試運転における潮流補正方法」 Mr. Myung Soo Shin (Korea Institute of Ocean Science & Technology)、韓国
2	「EEDI 検証に用いる ISO15016 の改正作業の現状－速力試運転の実施及び解析方法」 石黒 剛 (ジャパンマリンユナイテッド)、日本
大気汚染防止	
3	「Sox 及び NOx 規制の影響、ECA 及び NOx 三次規制の実施、全般的な最近の動向」 中尾 徹 (日立造船株式会社)、日本
4	「2 ストロークディーゼルエンジンにおける環境対応の最新技術」 平岡 直大 (三菱重工船用機械エンジン株式会社)、日本
バラスト水管理	
5	「少バラスト水船舶に関する大連船舶重工の調査及び設計」 Mr. Bao Yan (Dalian Shipbuilding Industry Engineering and Research Institute)、中国
6	「船舶のバラスト水処理に対する光触媒技術の応用」 Mr. Zhang Daiyi (6354 Institute of China State Shipbuilding Corporation)、中国

◆ レセプション 19:00～ “コンチェルト”

第2日 11月8日 (金)

◆ 総括 9:30-12:00 於 瑞天 議長 岩本 洋 (一般社団法人日本造船工業会)

- 09:30-09:50 ASEFの外部連携 (含むIMO次世代船舶安全シンポジウム)
北村 欧 (三菱重工業株式会社、日本造船工業会)
- 09:50-10:20 安全分科会の報告
Mr. Wu Jiameng (MARIC)
- 10:20-10:50 環境分科会の報告
Mr. Choi Byeong-cheol(KOSHIPA)
- 10:50-11:00 次回年次会合に関する発表
第8回ASEFの主催者
- 11:00-11:20 休憩
- 11:20-11:50 第7回ASEFのまとめ
岩本 洋 議長
- 11:50-12:00 閉会の辞
愛川 展功 (一般財団法人日本船舶技術研究協会理事長)

◆ 昼食 12:00-13:00 於 海王

List of Participants

(As of 28 October 2013)

1. Bangladesh

	Family name	Given name	Organization
1	Mr. K. M. Mahmudur	Rahman	Bangladesh Shipbuilders Association
2	Mr. Mohammad	Nasir	Bangladesh Shipbuilders Association

2. China

	Family name	Given name	Organization
1	Mr. Yu	Shichun	China Association of the National Shipbuilding Industry
2	Mr. Qian	Xinnan	China Association of the National Shipbuilding Industry
3	Mrs. Shen	Suijia	China Association of the National Shipbuilding Industry
4	Mrs. Tan	Naifen	China Association of the National Shipbuilding Industry
5	Ms. Wu	Chunping	Shipbuilding Technology Research Institute
6	Mr. Wen	Baohua	GreenSeas marine Technology Co., Ltd. Shanghai, China
7	Mr. Bao	Yan	Dalian Shipbuilding Industry Co., Ltd.
8	Mr. Chen	Han	Dalian Shipbuilding Industry Co., Ltd.
9	Mr. Bai	Yugang	China Ship Design & Research Center Co., Ltd.
10	Mr. Fan	Wei	China Shipbuilding Information Center
11	Mr. Fan	Yunzhi	China Classification Society
12	Mr. Zhao	Zhijian	COSCO Shipyard Group Co., Ltd.
13	Mr. Wu	Jiameng	Marine Design & Research Institute of China
14	Mr. Zhang	Daiyi	6354 institute of China State Shipbuilding Corporation

3. Ghana

	Family name	Given name	Organization
1	Mr. Alipui	Samuel	Sya Sea Limited

4. Indonesia

	Family name	Given name	Organization
1	Mr. Said	Novirwan	IPERINDO
2	Mr. Wirjawan	Wing	IPERINDO
3	Mr. Joeswanto	Karijodimedjo	PT Janata Marina Indah

4	Mr. Silitonga	Immanuel Hamonangan ^T	Ministry of Industry
5	Mr. Tomo	Brigantono	PT. TOMO & SON
6	Mr. Syamsuddin	Hasbi Assiddiq	Maritime Aerospace Affairs And Defence Equipment Industries
7	Mr. Hoedojo	Hoetomo	PT. SCORPA PRANEDYA
8	Mr. Gunawan	Amir	PT. DAYA RADAR UTAMA
9	Mr. Tomo	Riyo D	PT. TOMO & SON
10	Mr. Affandi	Mohammad	PT. DAYA RADAR UTAMA

5. Korea

	Family name	Given name	Organization
1	Mr. Kang	Sa-Joon	Korea Offshore and Shipbuilding Association
2	Mr. Choi	Byeong-cheol	Korea Offshore and Shipbuilding Association
3	Mr. Kim	Sung-Hyun	Korea Offshore and Shipbuilding Association
4	Mr. Shin	Jung Gyu	Korea Offshore and Shipbuilding Association
5	Dr. Shin	Myung-Soo	Korea Institute of Ocean Science & Technology
6	Mr. Lee	Jaemoo	Samsung Heavy Industries
7	Mr. Park	Moon-sun	Korean Register of Shipping
8	Mr. Kim	John	Aggreko South Korea Ltd
9	Dr. Kim	Chang-wook	Korean Register of Shipping

6. Malaysia

	Family name	Given name	Organization
1	Mr. Yong	King Hwa (Renco)	Association of Marine Industries Of Malaysia (AMIM)

7. Philippines

	Family name	Given name	Organization
1	Mr. Lignes	Rey	Sectoral Studies Division Manufacturing Industries Department

8. Singapore

	Family name	Given name	Organization
1	Mr. Sonoda	Yuich	Asian Shipowners' Forum
2	Mr. Tan	Elvin	Asian Shipowners' Forum

9. Sri Lanka

	Family name	Given name	Organization
1	Mr. Nakauchi	Akihiko	Colombo Dockyard PLC
2	Mr. Deiyandara	Abeysinghe	Colombo Dockyard PLC

10. Thailand

	Family name	Given name	Organization
1	Mr. Wacharapinyo	Wasin	Asian Marine Services Public Co., Ltd (ASIMR)

11. Japan

	Family name	Given name	Organization
1	Mr. Murayama	Shigeru	Kawasaki Heavy Industries, Ltd.
2	Mr. Kobayashi	Kazuya	Kawasaki Heavy Industries, Ltd.
3	Dr. Takaoka	Yukichi	Kawasaki Heavy Industries, Ltd.
4	Mr. Ebira	Kazuyuki	Kawasaki Heavy Industries, Ltd.
5	Mr. Motoi	Tatsuya	Kawasaki Heavy Industries, Ltd.
6	Mr. Kashiwa	Shinichiro	Kawasaki Heavy Industries, Ltd.
7	Mr. Hotta	Jumpei	Kawasaki Heavy Industries, Ltd.
8	Mr. Toma	Yoshihiko	Kawasaki Heavy Industries, Ltd.
9	Mr. Ogawa	Mitsuchika	Kawasaki Heavy Industries, Ltd.
10	Mr. Kiyosue	Takaaki	Kawasaki Heavy Industries, Ltd.
11	Mr. Matsubara	Naoya	Kawasaki Heavy Industries, Ltd.
12	Mr. Hamano	Tetsuya	Kawasaki Heavy Industries, Ltd.
13	Mr. Yamashita	Masaaki	Kawasaki Heavy Industries, Ltd.
14	Mr. Fukuda	Norihisa	Mitsui Engineering & Shipbuilding Co., Ltd.
15	Mr. Tsubokawa	Takehiko	Mitsui Engineering & Shipbuilding Co., Ltd.
16	Mr. Yamamoto	Koutaku	Mitsui Engineering & Shipbuilding Co., Ltd.
17	Mr. Ueda	Naoki	Mitsubishi Heavy Industries, Ltd.
18	Mr. Unseki	Takashi	Mitsubishi Heavy Industries, Ltd.
19	Mr. Kitamura	O	Mitsubishi Heavy Industries, Ltd.
20	Mr. Yumura	Kouichi	Mitsubishi Heavy Industries, Ltd.
21	Mr. Tanaka	Taichi	Mitsubishi Heavy Industries, Ltd.

22	Mr. Iwamoto	Hiroshi	Japan Marine United Corporation
23	Mr. Toyota	Muneharu	Japan Marine United Corporation
24	Mr. Ishiguro	Tsuyoshi	Japan Marine United Corporation
25	Mr. Shibasaki	Kohta	Japan Marine United Corporation
26	Mr. Hirota	Kazuyoshi	Japan Marine United Corporation
27	Mr. Takai	Michio	Sumitomo Heavy Industries Marine &Engineering Co., Ltd.
28	Mr. Fujii	Yasunari	Sanoyas Shipbuilding Corporation
29	Mr. Fujii	Toshihiro	Oshima Shipbuilding Co., Ltd.
30	Dr. He	Qing	Oshima Shipbuilding Co., Ltd.
31	Mr. Kamita	Kenji	Imabari Shipbuilding Co., Ltd.
32	Dr. Furuno	Hiroshi	Namura Shipbuilding Co., Ltd.
33	Mr. Yamamoto	Yasuhiro	Namura Shipbuilding Co., Ltd.
34	Mr. Obata	Hideo	Namura Shipbuilding Co., Ltd.
35	Dr. Kashiro	Riki	Namura Shipbuilding Co., Ltd.
36	Dr. Uchimura	Hideyuki	Shin Kurushima Dockyard Co., Ltd.
37	Mr. Nakao	Toru	Hitachi Zosen Corporation
38	Dr. Arima	Toshiro	Nippon Kaiji Kyokai
39	Mr. Suga	Hayato	Nippon Kaiji Kyokai
40	Mr. Nishifuji	Koichi	Nippon Kaiji Kyokai
41	Mr. Tamura	Yuki	Nippon Kaiji Kyokai
42	Mr. Yamasaki	Masao	Nippon Kaiji Kyokai
43	Ms. Hayano	Ayana	Nippon Kaiji Kyokai
44	Mr. Gyobu	Seiichi	Nippon Kaiji Kyokai
45	Mr. Yoshimura	Kenshi	Nippon Kaiji Kyokai
46	Mr. Fujinami	Yukihito	Nippon Kaiji Kyokai
47	Ms. Ogawa	Tomomi	Nippon Kaiji Kyokai
48	Mr. Tokunaga	Shingo	Nippon Kaiji Kyokai
49	Mr. Ishimura	Kotaro	Kawasaki Kisen Kaisha, Ltd.
50	Mr. Hiraoka	Naohiro	Mitsubishi Heavy Industries Marine Machinery & Engine Co., Ltd.
51	Mr. Matsumoto	Kenichi	Aggreko Japan KK

52	Mr. Hasebe	Yoshinori	Aggreko Japan KK
53	Mr. Kawai	Hiroyasu	Lloyd's Register Group Limited (Yokohama Office)
54	Mr. Takita	Kazuma	GEA Westfalia Separator Japan K.K.
55	Mr. Okihara	Masaki	VOLCANO Co., Ltd.
56	Mr. Yokota	Yasuo	Teikoku Machinery Works Ltd.
57	Mr. Nakazaki	Masatoshi	Nakashima Propeller Co., Ltd.
58	Mr. Fukaya	Shogo	Daikin MR Engineering Co., Ltd.
59	Mr. Watanabe	Keisuke	Daikin MR Engineering Co., Ltd.
60	Mr. Fujiwara	Naoto	HSN-KIKAI KOGYO CO., LTD.
61	Mr. Ando	Noboru	Ministry of land, Infrastructure, Transport and Tourism
62	Mr. Handa	Hideya	Ministry of land, Infrastructure, Transport and Tourism
63	Mr. Umeda	Hisahito	DAILY THE KAIJI
64	Mr. Yokokawa	Ryoji	KAIJI PRESS Co., Ltd.
65	Mr. Kiriake	Kimio	The Shipbuilders' Association of Japan
66	Mr. Munechika	Hidenori	The Shipbuilders' Association of Japan
67	Mr. Yoshikawa	Masayuki	The Shipbuilders' Association of Japan
68	Mr. Yamaguchi	Yuji	The Shipbuilders' Association of Japan
69	Mr. Matsuda	Akira	Japan Ship Technology Research Association
70	Mr. Aikawa	Nobuyoshi	Japan Ship Technology Research Association
71	Mr. Tanaka	Morifumi	Japan Ship Technology Research Association
72	Mr. Okamuara	Bin	Japan Ship Technology Research Association
73	Mr. Ishihara	Akira	Japan Ship Technology Research Association
74	Mr. Ogasahara	Tomoyuki	Japan Ship Technology Research Association
75	Ms. Nishimura	Eriko	Japan Ship Technology Research Association
76	Mr. Nagasawa	Tadao	Japan Ship Technology Research Association
77	Mr. Hasegawa	Kosei	Japan Ship Technology Research Association
78	Mr. Matsumoto	Reita	Japan Ship Technology Research Association
79	Mr. Uosaki	Yoshiro	Japan Ship Technology Research Association
80	Ms. Fukushima	Mamiko	Japan Ship Technology Research Association

Bangladesh	China	Ghana	Indonesia	Korea	Malaysia
2	14	1	10	9	1
Philippines	Singapore	Sri Lanka	Thailand	Japan	TOTAL
1	2	2	1	80	123



Organizers

Japan Ship Technology Research Association (JSTRA)

The Shipbuilders' Association of Japan (SAJ)

Co-organizers

Korea Offshore and Shipbuilding Association (KOSHIPA)

China Association of the National Shipbuilding Industry (CANSI)